

XMTM PFP Hot Water Flush Kit

332073C
EN

For flushing the XM PFP system with hot water. For professional use only.

*100 psi (0.7 MPa, 7 bar) Maximum Inlet Water Pressure to Float Valve
180°F (82°C) Maximum Outlet Fluid Temperature*



Important Safety Instructions

Read all warnings and instructions in this manual and the XM PFP Operation manual. Save all instructions.

See Models, page 2 for more information.

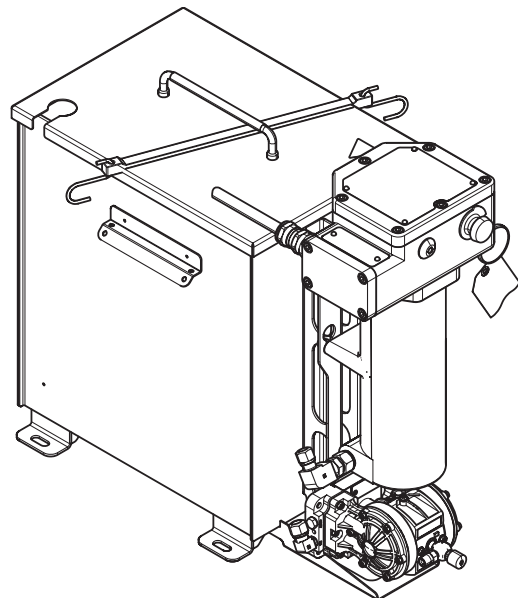

ti25772a

Contents

Related Manuals 2
Models 2
Component Identification 3
Installation 4
Connect Air Supply 6
Connect Water Supply 6
Priming the Heater 7
Parts 8
Technical Data 10
Graco Standard Warranty 12

Related Manuals



Manual	Description
3A2776	XM PFP Operation
3A2989	XM PFP Repair-Parts
308652	Husky™ 205 Air-Operated Diaphragm Pumps, Instructions-Parts
309524	Viscon® HP Heater, Instructions-Parts



Models

Part No.	Description
24X113	Hazardous Location Hot Water Flush Kit
24Y132	Non Hazardous Location Hot Water Flush Kit

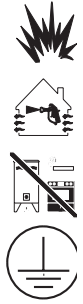
Warnings

The following warnings are for the setup, use, grounding, maintenance, and repair of this equipment. The exclamation point symbol alerts you to a general warning and the hazard symbols refer to procedure-specific risks. When these symbols appear in the body of this manual or on warning labels, refer back to these Warnings. Product-specific hazard symbols and warnings not covered in this section may appear throughout the body of this manual where applicable.

	<p>FIRE AND EXPLOSION HAZARD</p> <p>Flammable fumes, such as solvent and paint fumes, in work area can ignite or explode. Paint or solvent flowing through the equipment can cause static sparking. To help prevent fire and explosion:</p> <ul style="list-style-type: none"> • Use equipment only in well ventilated area. • Eliminate all ignition sources; such as pilot lights, cigarettes, portable electric lamps, and plastic drop cloths (potential static sparking). • Ground all equipment in the work area. See Grounding instructions. • Never spray or flush solvent at high pressure. • Keep work area free of debris, including solvent, rags and gasoline. • Do not plug or unplug power cords, or turn power or light switches on or off when flammable fumes are present. • Use only grounded hoses. • Hold gun firmly to side of grounded pail when triggering into pail. Do not use pail liners unless they are anti-static or conductive. • Stop operation immediately if static sparking occurs or you feel a shock. Do not use equipment until you identify and correct the problem. • Keep a working fire extinguisher in the work area.
	<p>ELECTRIC SHOCK HAZARD</p> <p>This equipment must be grounded. Improper grounding, setup, or usage of the system can cause electric shock.</p> <ul style="list-style-type: none"> • Turn off and disconnect power at main switch before disconnecting any cables and before servicing or installing equipment. • Connect only to grounded power source. • All electrical wiring must be done by a qualified electrician and comply with all local codes and regulations.
	<p>SKIN INJECTION HAZARD</p> <p>High-pressure fluid from gun, hose leaks, or ruptured components will pierce skin. This may look like just a cut, but it is a serious injury that can result in amputation. Get immediate surgical treatment.</p> <ul style="list-style-type: none"> • Do not spray without tip guard and trigger guard installed. • Engage trigger lock when not spraying. • Do not point gun at anyone or at any part of the body. • Do not put your hand over the spray tip. • Do not stop or deflect leaks with your hand, body, glove, or rag. • Follow the Pressure Relief Procedure when you stop spraying and before cleaning, checking, or servicing equipment. • Tighten all fluid connections before operating the equipment. • Check hoses and couplings daily. Replace worn or damaged parts immediately.

	<p>BURN HAZARD</p> <p>Equipment surfaces and fluid that's heated can become very hot during operation. To avoid severe burns:</p> <ul style="list-style-type: none"> • Do not touch hot fluid or equipment.
	<p>EQUIPMENT MISUSE HAZARD</p> <p>Misuse can cause death or serious injury.</p> <ul style="list-style-type: none"> • Do not operate the unit when fatigued or under the influence of drugs or alcohol. • Do not exceed the maximum working pressure or temperature rating of the lowest rated system component. See Technical Data in all equipment manuals. • Use fluids and solvents that are compatible with equipment wetted parts. See Technical Data in all equipment manuals. Read fluid and solvent manufacturer's warnings. For complete information about your material, request Safety Data Sheet (SDS) from distributor or retailer. • Do not leave the work area while equipment is energized or under pressure. • Turn off all equipment and follow the Pressure Relief Procedure when equipment is not in use. • Check equipment daily. Repair or replace worn or damaged parts immediately with genuine manufacturer's replacement parts only. • Do not alter or modify equipment. Alterations or modifications may void agency approvals and create safety hazards. • Make sure all equipment is rated and approved for the environment in which you are using it. • Use equipment only for its intended purpose. Call your distributor for information. • Route hoses and cables away from traffic areas, sharp edges, moving parts, and hot surfaces. • Do not kink or over bend hoses or use hoses to pull equipment. • Keep children and animals away from work area. • Comply with all applicable safety regulations.
	<p>PERSONAL PROTECTIVE EQUIPMENT</p> <p>Wear appropriate protective equipment when in the work area to help prevent serious injury, including eye injury, hearing loss, inhalation of toxic fumes, and burns. This protective equipment includes but is not limited to:</p> <ul style="list-style-type: none"> • Protective eyewear, and hearing protection. • Respirators, protective clothing, and gloves as recommended by the fluid and solvent manufacturer

Component Identification

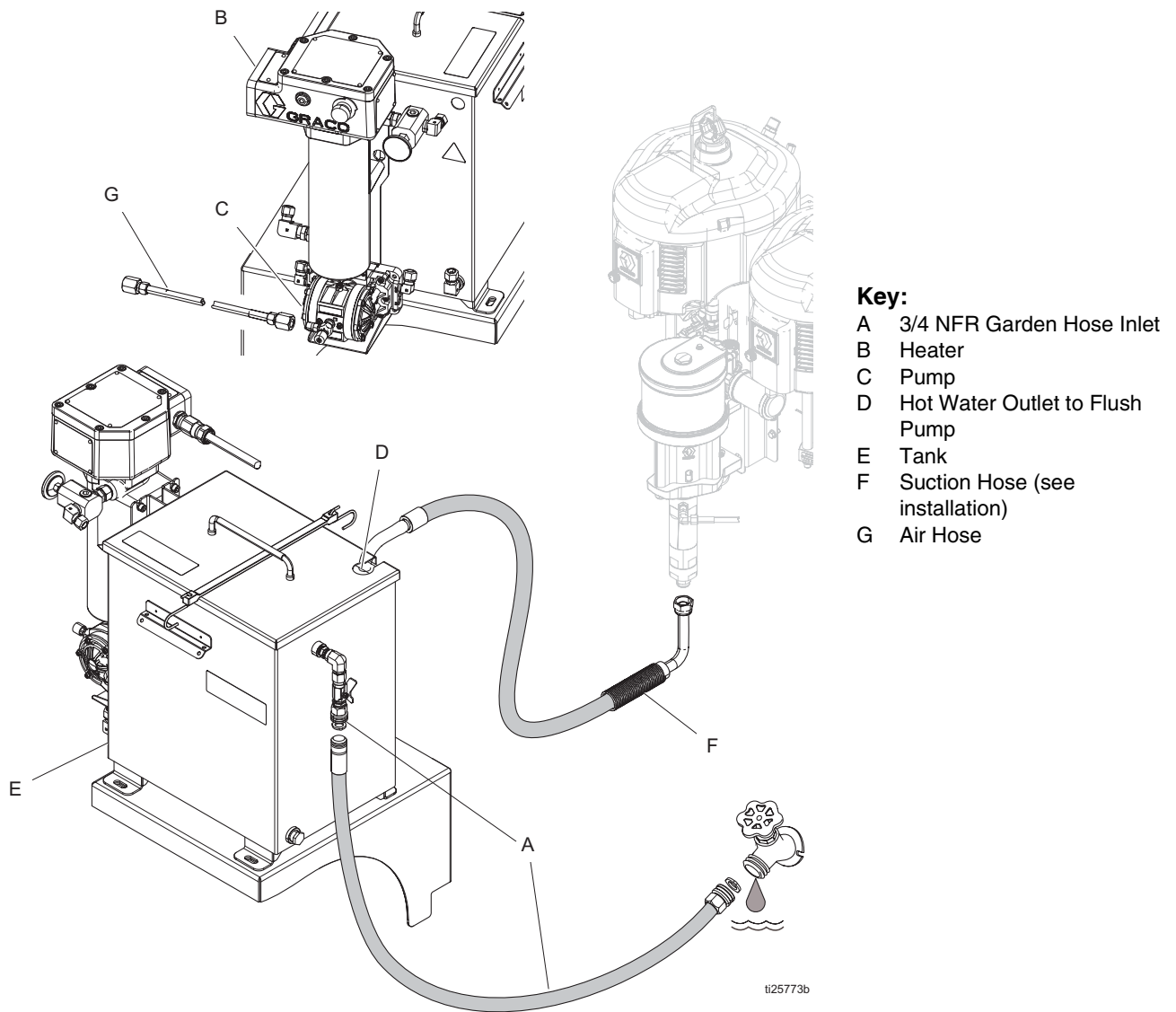
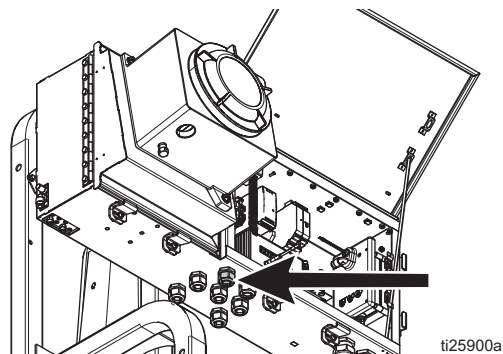

FIG. 1

Hazardous Location XM PFP



Non-Hazardous Location XM PFP

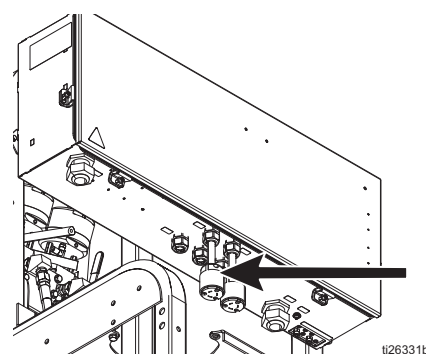

FIG. 2: Heater Power Cable

Installation



The equipment must be grounded to reduce the risk of static sparking and electric shock. Electric or static sparking can cause fumes to ignite or explode. Improper grounding can cause electric shock. Grounding provides an escape wire for the electric current.

Optional Location 1

See FIG. 1 on page 5 and FIG. 3.

1. Use four bolts (4) to install the bracket (2) onto the system frame.

2. Use four bolts and nuts (4, 5) to install tank (1) onto bracket (2).
3. Follow **Connect Air Supply**, page 8. Connect air hose (8) to circulation pump (53) and diaphragm pump (P) on the PFP system.
4. Connect suction hose (F) to the flush pump and insert in the hot water flush tank.
5. Connect heater power cable.
 - a. *Model 24Y132:* With the heater ON/OFF toggle switch (H) OFF, connect power cable to the corded receptacle hanging below the junction box on the XM PFP sprayer.
 - b. *Model 24X113:* With the heater ON/OFF toggle switch (H) OFF, route the heater power cable through the Flush Heater cord grip. See FIG. 2, page 5. See system manual for power connection.

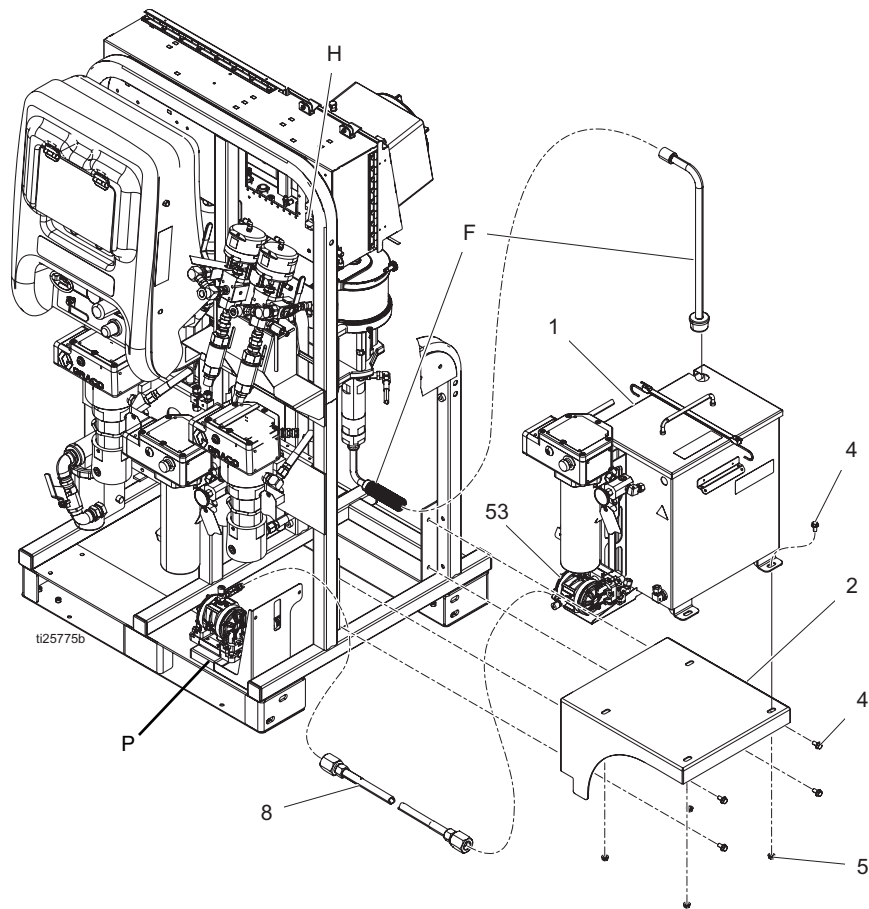

FIG. 3: Optional Location 1

Connect Air Supply

1. Disconnect air supply (AS) from Heated Fluid Circulation Pump (P) for hose bundle.
2. For Model 24Y132: install the tee (9), nipple (10). The cap (11) is not used.

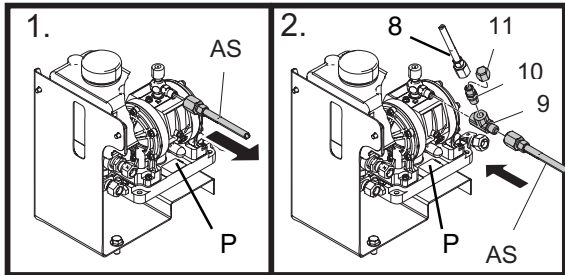
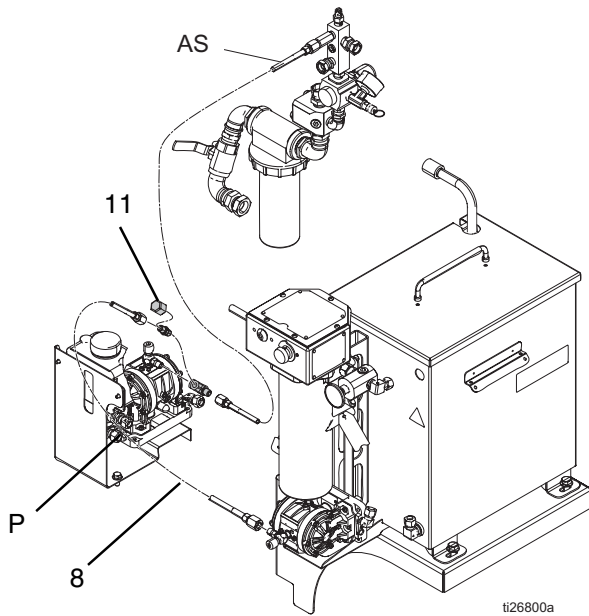

FIG. 5:

3. For Model 24X113:
 - a. Remove cap (11).
4. Connect air hose (8) to circulation pump (53) and diaphragm pump (P) on the PFP system. See FIG. 3 on page 6 or FIG. 4 on page 7.

5. Connect the air hose (8) to the nipple fitting (10). See #2 in FIG. 5. Connect the air hose (8) to the hot water circulation pump (53).

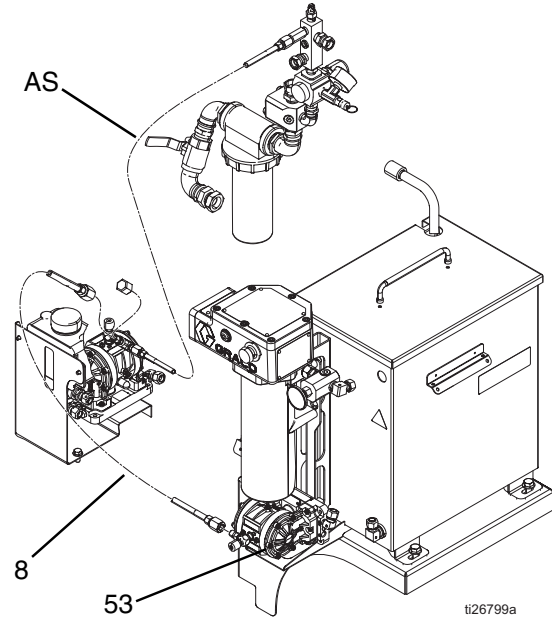







FIG. 6:

Connect Water Supply

1. Connect garden hose to a water supply and the water inlet (A). See FIG. 1, page 5.

Priming the Heater

					
<p>Equipment surfaces and fluid that is heated can become very hot during operation. To avoid burns and fire and explosions:</p> <ul style="list-style-type: none"> • Do not touch hot fluid or equipment. • Only use water. 					

NOTICE
<p>To prevent damaging the heater element, never turn on the heater without it completely filled with water.</p>

1. Turn on water supply.
2. Loosen needle valve on diaphragm pump to pump water through the heater.
3. Turn the heated water flush switch on the XM PFP sprayer to the ON position. The switch is located next to the main power switch above the dosing valves.

NOTICE
<p>To prevent damage to the diaphragm pump, never turn the heater dial past 9.</p>

4. Use the dial on the heater to set desired temperature. See table.

Heater Dial	Tank Temperature °F(°C)
9	180 (82)
8	160 (71)
7	140 (60)
6	120 (48)
5	100 (37)

5. Turn on XM PFP flush pump ON to begin running water through the pump.
6. Spray until the water is dispensed from the gun.
7. Continue flushing as necessary.

Parts

Hazardous Location Hot Water Flush Kit, 24X113 Non Hazardous Location Hot Water Flush Kit, 24Y132

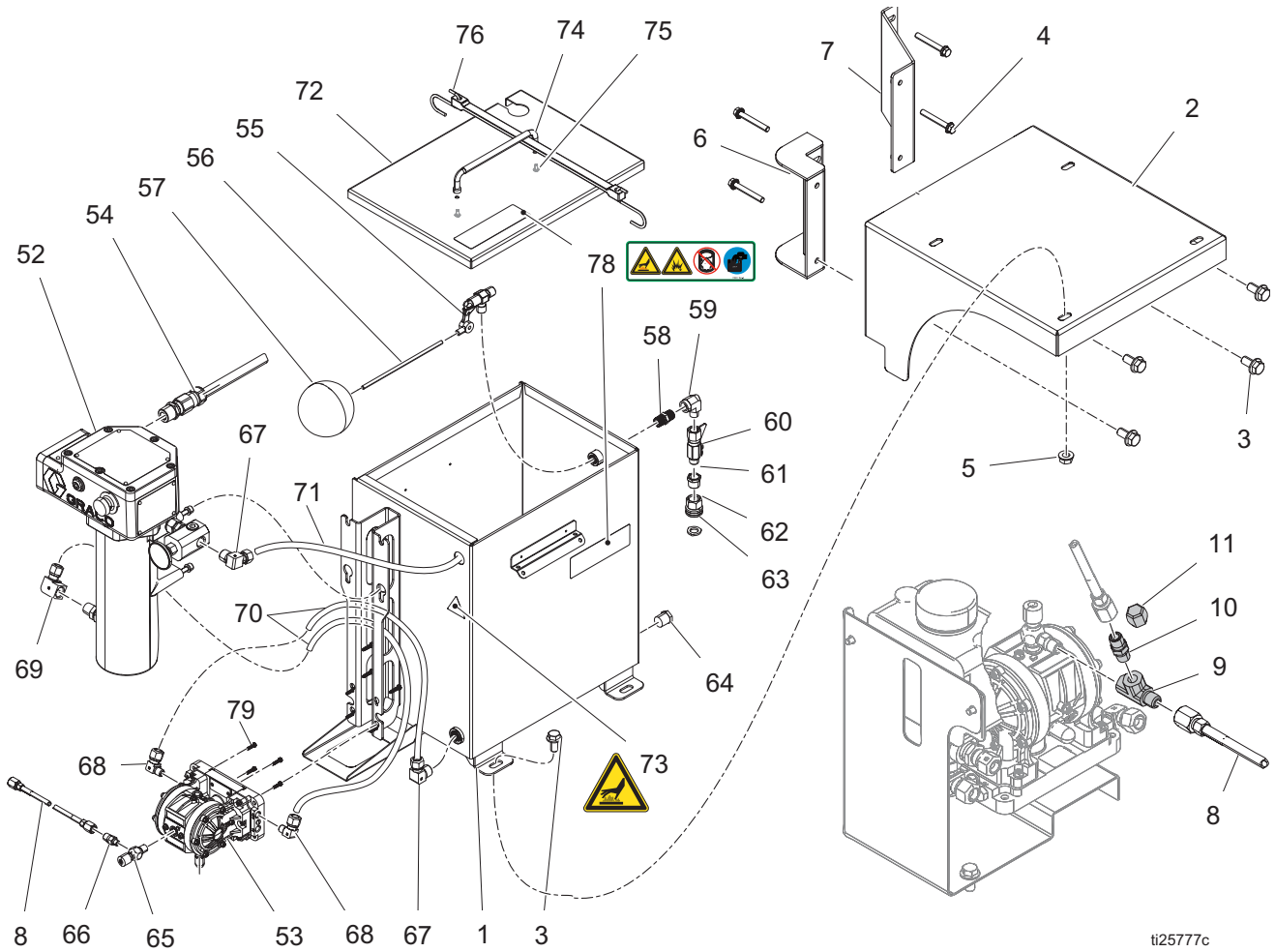

ti25777c

NOTE: Use sealant on all pipe threads.

Hazardous Hot Water Flush Kit, 24X113
Non Hazardous Hot Water Flush Kit, 24Y132

Ref	Part	Description	Qty
1	262937	TANK, heated, water	1
	262946	TANK, heated water	1
2	17B717	BRACKET, mount	1
3	121488	SCREW, hex head, flanged	4
4	112395	SCREW, cap, flange head	8
5	112958	NUT, hex, flanged	4
6	256254	BRACKET, hopper, b-mt	1
7	256256	BRACKET, hopper, b-mt, lower	1
8	248208	HOSE, coupled, 4 ft (1.2 m)	1
9	116504	FITTING, tee, run, 1/4 npt(m) x 1/4 npt(m) x 1/4 npt(f)	1
10	156971	FITTING, nipple, short, 2 x 1/4-18 npt	1
11	16X167	FITTING, cap, hex 1/4 npt(f)	1

--- Not for sale.

▲ Replacement Danger and Warning labels, tags and cards are available at no cost.

Hazardous Water Heated Tank, 262937
Non Hazardous Water Heated Tank, 262946

Ref	Part	Description	Qty
51	17B562	TANK, heated, water	1
52	245863	HEATER (262937 only)	1
	245869	HEATER (262946 only)	1
53	24T761	PUMP, Husky	1
54	24W679	CABLE, assembly (262937 only)	1
	17G071	CABLE, assembly (262946 only)	1
55*	24W654	VALVE, body, float	1
56*	24W655	ROD, float, 8 in (203 mm)	1
57*	24W656	FLOAT, round, copper	1
58	156849	PIPE, nipple	1
59	111856	FITTING, elbow, street	1
60	237534	VALVE, ball, 316 sst	1
61	100081	BUSHING, pipe	1
62	16T886	ADAPTER, 3/4 NFR to 1/2 npt	1
63	115099	WASHER, garden hose	1
64	16G248	FITTING, plug, 1/2 npt	1
65	206264	VALVE, needle	1
66	16D939	FITTING, nipple, reducing	1
67	126898	FITTING, elbow, 1/2 tube x 1/2 nptm	2
68	126897	FITTING, elbow, 1/2 tube x 1/4 nptm	1
69	126896	FITTING, elbow, 1/2 tube x 1/2 nptf	1
70	---	TUBE, blue, nylon 0.375 (9.5 mm) ID; 3 ft (1 m)	1
71	---	TUBE, red, nylon 0.375 (9.5 mm) ID; 1 ft (0.3 m)	1
72	17B563	COVER, tank	1
73▲	189285	LABEL, hot	1
74	117499	HANDLE, large	1
75	106084	SCREW, mach, pn hd	2
76	17C670	STRAP, rubber, 19 in (482.6 mm)	1
77	121603	GRIP, cord (262946 only)	1
78▲	17D817	LABEL, safety, warning, water only	2
79	17D135	SCREW, hex, hi-lo, thread forming	4

▲ Replacement Danger and Warning labels, tags and cards are available at no cost.

* Parts included in the Water Rod Float Valve Kit 24Y096.

Technical Data

PFP Hot Water Flush Kit		
	US	Metric
Maximum Water Inlet Pressure to Float Valve	100 psi	7 MPa, 7 bar
Maximum Outlet Fluid Temperature	180°F	82°C
Supply Voltage	220-250 Volts AC, 1 phase	
Power	4000 Watts	
Tank Size	10 gallon	37.8 liter
Inlet Fitting	3/4 NHR Garden Hose	
Wetted Parts	Plated Carbon steel, stainless steel, brass	

Graco Standard Warranty

Graco warrants all equipment referenced in this document which is manufactured by Graco and bearing its name to be free from defects in material and workmanship on the date of sale to the original purchaser for use. With the exception of any special, extended, or limited warranty published by Graco, Graco will, for a period of twelve months from the date of sale, repair or replace any part of the equipment determined by Graco to be defective. This warranty applies only when the equipment is installed, operated and maintained in accordance with Graco's written recommendations.

This warranty does not cover, and Graco shall not be liable for general wear and tear, or any malfunction, damage or wear caused by faulty installation, misapplication, abrasion, corrosion, inadequate or improper maintenance, negligence, accident, tampering, or substitution of non-Graco component parts. Nor shall Graco be liable for malfunction, damage or wear caused by the incompatibility of Graco equipment with structures, accessories, equipment or materials not supplied by Graco, or the improper design, manufacture, installation, operation or maintenance of structures, accessories, equipment or materials not supplied by Graco.

This warranty is conditioned upon the prepaid return of the equipment claimed to be defective to an authorized Graco distributor for verification of the claimed defect. If the claimed defect is verified, Graco will repair or replace free of charge any defective parts. The equipment will be returned to the original purchaser transportation prepaid. If inspection of the equipment does not disclose any defect in material or workmanship, repairs will be made at a reasonable charge, which charges may include the costs of parts, labor, and transportation.

THIS WARRANTY IS EXCLUSIVE, AND IS IN LIEU OF ANY OTHER WARRANTIES, EXPRESS OR IMPLIED, INCLUDING BUT NOT LIMITED TO WARRANTY OF MERCHANTABILITY OR WARRANTY OF FITNESS FOR A PARTICULAR PURPOSE.

Graco's sole obligation and buyer's sole remedy for any breach of warranty shall be as set forth above. The buyer agrees that no other remedy (including, but not limited to, incidental or consequential damages for lost profits, lost sales, injury to person or property, or any other incidental or consequential loss) shall be available. Any action for breach of warranty must be brought within two (2) years of the date of sale.

GRACO MAKES NO WARRANTY, AND DISCLAIMS ALL IMPLIED WARRANTIES OF MERCHANTABILITY AND FITNESS FOR A PARTICULAR PURPOSE, IN CONNECTION WITH ACCESSORIES, EQUIPMENT, MATERIALS OR COMPONENTS SOLD BUT NOT MANUFACTURED BY GRACO. These items sold, but not manufactured by Graco (such as electric motors, switches, hose, etc.), are subject to the warranty, if any, of their manufacturer. Graco will provide purchaser with reasonable assistance in making any claim for breach of these warranties.

In no event will Graco be liable for indirect, incidental, special or consequential damages resulting from Graco supplying equipment hereunder, or the furnishing, performance, or use of any products or other goods sold hereto, whether due to a breach of contract, breach of warranty, the negligence of Graco, or otherwise.

FOR GRACO CANADA CUSTOMERS

The Parties acknowledge that they have required that the present document, as well as all documents, notices and legal proceedings entered into, given or instituted pursuant hereto or relating directly or indirectly hereto, be drawn up in English. Les parties reconnaissent avoir convenu que la rédaction du présente document sera en Anglais, ainsi que tous documents, avis et procédures judiciaires exécutés, donnés ou intentés, à la suite de ou en rapport, directement ou indirectement, avec les procédures concernées.

Graco Information

For the latest information about Graco products, visit www.graco.com.

TO PLACE AN ORDER, contact your Graco distributor or call to identify the nearest distributor.

Phone: 612-623-6921 **or Toll Free:** 1-800-328-0211 **Fax:** 612-378-3505

*All written and visual data contained in this document reflects the latest product information available at the time of publication.
Graco reserves the right to make changes at any time without notice.*

For patent information, see www.graco.com/patents.

Original instructions. This manual contains English. MM 332073

Graco Headquarters: Minneapolis
International Offices: Belgium, China, Japan, Korea

GRACO INC. AND SUBSIDIARIES • P.O. BOX 1441 • MINNEAPOLIS MN 55440-1441 • USA

Copyright 2012, Graco Inc. All Graco manufacturing locations are registered to ISO 9001.

www.graco.com

Revision C, July 2015